

- Please read all instructions completely before starting any part of the installation.
- Each railing kit comes complete with all parts, hardware and installation guide to install one complete rail section (excluding posts.) Railing sections have been pre-cut to 6 ft. or 8 ft. lengths. Check to ensure that the kit is complete.
- AZEK Rail should be installed using the same good building principles used to install wood or composite railing and in accordance with the local building codes and the installation guidelines included below. AZEK Building Products Inc. claims no liability or responsibility for the improper installation of this product.
- AZEK Rail may not be suitable for every application and it is the sole responsibility of the installer to be sure that AZEK Rail is fit for the intended use. Since all installations are unique, it is also the installer's responsibility to determine specific requirements in regards to each Rail application.
- AZEK Building Products recommends that all designs be reviewed by a licensed architect, engineer or local building official before installation. If you have any questions or need further assistance, please call AZEK Customer Service at 877-ASK-AZEK (877-275-2935) or visit our website at www.azek.com.
- AZEK Railing is tested as a whole system and should be used that way. It is not intended to be used in conjunction with other railing systems or fasteners.
- **IMPORTANT:** Make sure the DRIVE TOOL/DRILL is configured or set to use the SCREW setting when driving and/or tightening all FASTENERS.
- **SAFETY:** Always wear goggles when handling, cutting, drilling and fastening materials.
- **NOTE:** Check local code requirements prior to installation.

NOTE: UNIVERSAL BRACKETS are needed for installations involving compound rail angles. For simple stair angles use brackets included in Stair Rail kits.

Tools Required

- Pencil
- Measuring Tape
- Drill
- Mitre Saw fitted with a high tooth count finish carpentry blade
- 7/16" Wrench
- 1/8" Drill Bit
- 3/16" Drill Bit
- 5/16" Drill Bit
- 3/8" Drill Bit
- Scrap Length of Wood

Hardware

- (4) Stair Brackets
- (2) Spring Clip Threaded Plate Retainer
- (1) Spring Clip Installation Tool
- (8) 5/8" #10 Machine Screws
- (2) Threaded Plates
- (1) T-25 Bit
- (28) Baluster Screws
- (5) 1" #8 Wood Screws
- (8) 2 1/2" #10 Wood Screws
- Universal Bracket Pack**
 - (4) Lag Screws
 - (4) Balls
 - (4) Brackets
 - (4) Cups

Recommended

- Impact Driver
- Speed Square

Parts

Trademark Profiles Shown throughout Instructions

- Premier Profiles
- Reserve Profiles
- (1) Handrail
- (1) Bottom Rail
- (1) Top Retainer
- (13) Balusters

IMPORTANT

Make sure that the DRIVE TOOL/DRILL is configured or set to use the SCREW setting when driving and/or tightening all FASTENERS.

1 Prepare for post sleeves

WARNING: Post sleeves are not designed to be used in structural applications. Therefore, they should not be used where they may be subject to weight bearing applications such as supports for a roof of a porch or deck.

- The 4 x 4 should be completely "boxed in" around all 4 corners of the firmest attachment.
- Make sure posts are level and plumb.
- If post is twisted or oversized, trim as necessary so post sleeve slides easily over post. (Do not force sleeve over post)
- Post sleeves may also be used over wood posts installed with Surface Mount Bracket or Tallboy Surface Mount Bracket.
- Post sleeves should not be notched for installation.
- If installing using a Surface Mount Bracket or Tallboy Surface Mount Bracket, please refer to those specific installation instructions.
- **IMPORTANT:** Must check with local building code for proper installation of wood post and decking attachment.

2 Install Post Sleeves

Do not force the Post Sleeve over the 4" x 4" as it may eventually lead to a crack or split

3 Mark and Cut Scrap Wood to Find Rail Length & Angle

*** Before installing stair rail section, be sure section complies with local stair codes**

*** Tip**

- Ensure Posts are plumb
- Use Speed Square to assist in determining angles

*** Tip:** Once correct angles have been obtained, mark these angles on Mitre Saw for easy reference.

*** Be sure to measure rail length along center line of scrap**

Mark scrap from the outside of the angle to ensure adequate material length

After cutting compound angles, dry fit scrap wood between posts to verify proper length and angle

Once correct angle has been obtained, trim small amounts off scrap until it fits the correct angle and scrap is centered on the post.

Rail Length

4 Measure & Mark Bottom Rail Ensuring Proper Baluster Spacing

a Make Sure X=Y

b Make Sure X=Y

If X is greater than 5" baluster spacing will not meet code. Shift hole pattern from **a** to **b** by moving the scrap piece along the Bottom Rail until the distance X=Y again. Make sure X is greater than 2 1/2".

*** Tip:** Mark on centerline of dimpled surface to ensure accurate cuts and hole spacing

Most building codes require that a 4" sphere shall not pass through the rail at any point. To comply with the 4" sphere rule, a 6 ft. rail section must be cut a minimum of 7/8".

5 Measure & Mark Top Retainer Ensuring Proper Baluster Spacing

*** Tip**

Use X & Y measurements obtained in step 4

Mark on centerline of inside dimpled surface to ensure accurate hole spacing

Make Sure X=Y

6 Cut Top Retainer & Bottom Rail Angle

*** Tip**

Use saw set to the same angles as determined in step 3

*** Tip**

Because marks are on the inside surface of the top retainer, you may have to make a few test cuts and back in to your measured line.

7 Drill Baluster Holes in Top Retainer & Bottom Rail

Cut Scrap from step # 3

3/16" Drill Bit

*** Tip**

- Use Scrap wood from step 3 as a drill guide for properly angled baluster holes
- Drill through both top and bottom surfaces of the Bottom Rail with the 3/16" bit

8 Counter bore underside of Bottom Rail

3/8" Drill Bit

! When counter boring holes to create clearance for Baluster Screws, make sure to only drill through bottom surface of Bottom Rail

9 Measure, Mark & Drill for Brackets

! Using a piece of scrap, and the Universal Bracket Cup, mark the holes for the bracket flush with the end of the rail.

! Universal Brackets only need to be used on rails cut with compound angles. For installation of Stair Brackets, see STAIR RAILING INSTALLATION GUIDE.

! When drilling holes for Brackets, do not drill through top surface of Bottom Rail

! Now Pilot & Drill

Pilot with 1/8" Drill Bit
Drill with 5/16" Drill Bit

10 Install Brackets

! **IMPORTANT**
Make sure that the DRIVE TOOL/DRILL is configured or set to use the SCREW setting when driving and/or tightening all FASTENERS.

***** Remove Installation Tool before fully tightening bracket screws.

11 Trim Balusters

***** Longer balusters may be required in order to meet local code referring to top rail heights.

***** Tips:
When cutting balusters trim off as little material as possible to ensure a full length baluster. Use stop block on Mitre Saw for equal length balusters.

12 Assemble Rail Section: Fasten Balusters to Top Retainer & Bottom Rail

Rail assemblies from step # 8

Bottom Retainer 2nd

Top Retainer 1st

13 Mark Bracket, Remove Rail Section and Drill for Brackets

Mark Bracket locations using Universal Bracket Cup to locate hole

Mark all four Bracket locations and then remove rail section

! **WARNING:**
Be sure to check local code requirements for proper bottom rail location and top rail height and be sure that you have the proper height balusters to meet those requirements.

! **Important:**
• Be sure to only drill through Post Sleeve.
• Remove Rail Section before drilling holes.

Now Drill with 3/16" Drill Bit

14 Cut Post Sleeves

Cut Post Sleeve minimum 2" longer than desired railing height.

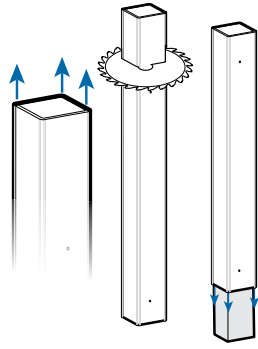

15 Remove Universal Brackets from Rail Section

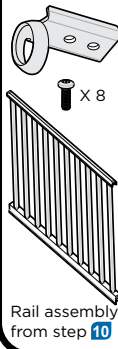
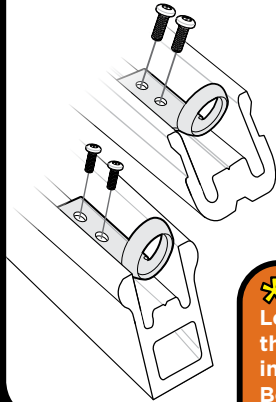

Tip
Leave the threaded plates installed on Bottom Rail.

16 Attach Universal Bracket Assemblies to Posts

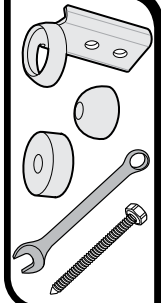
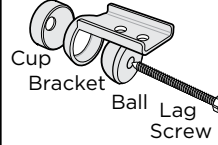

Loosen lag screw slightly to allow movement when installing rail section

Important:
Do not over torque screws when fastening Bracket to Posts as this may cause Post Sleeves to crack.

17 Attach Rail Section to Posts



IMPORTANT
Make sure that the DRIVE TOOL/DRILL is configured or set to use the SCREW setting when driving and/or tightening all FASTENERS.

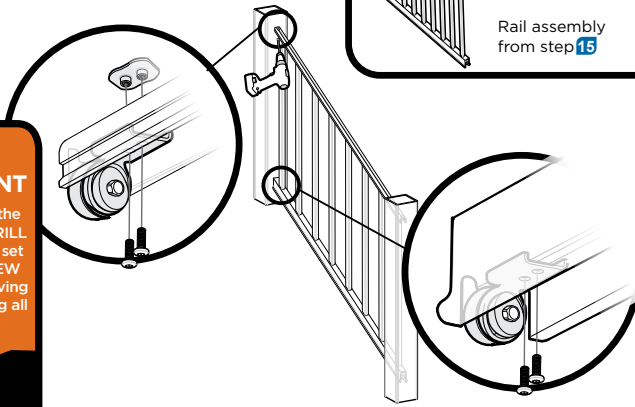

18 Tighten Universal Brackets



19 Measure & Cut Handrail

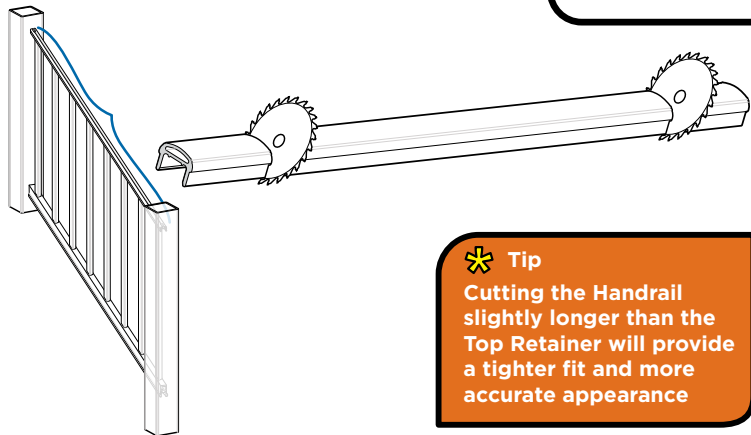

Tip
Cutting the Handrail slightly longer than the Top Retainer will provide a tighter fit and more accurate appearance

20 Attach Handrail to Top Retainer

